

Installation Instructions for EZflow Systems in Delaware



Infiltrator Systems Inc. requests approval from the State of Delaware Department of Natural Resources and Environmental Control, Ground Water Discharge Section for **EZflow** branded products 1201P-GEO, 1202H-GEO, and 1203H-GEO for use as part of a wastewater disposal system in the following applications as described in *The Regulations Governing The Design, Installation and Operation of On-site Wastewater Treatment and Disposal Systems*:

1. **Gravity Trenches and Beds**
 - a. Standard Trenches and Beds
 - b. Capping Fill Trenches and Beds
 - c. Sand-lined Trenches and Beds
2. **Pressure Dosed Trenches and Beds***
 - a. Full Depth Trenches and Beds
 - b. Capping Fill Trenches and Beds
 - c. Mound Systems
 - d. Low Pressure Pipe Systems**
 - e. Sand-lined Trenches and Beds

* **EZflow** 1202H-GEO and 1203H-GEO are designed to sleeve a pressurized distribution pipe within the four-inch perforated pipe present in the cylinder.

** For LPP systems a single pipe-containing cylinder, 1201-P-GEO, found in both 1202H-GEO and 1203H-GEO configurations is recommended for use.

Materials and Equipment needed

- **EZflow** Bundles
- **EZflow** Barrier Paper
- **EZflow** Internal Pipe Couplers
- **EZflow** Versa Couplers
- Pipe for Header and Inlet

Installation Instructions

The instructions for installation of **EZflow** products are given below. This product must be installed in accordance with Wastewater System and Potable Water Supply Rules, effective January 1, 2005 (Rules), as well as the local health department's current design manual.

1. The **EZflow** 1201-P-GEO product is 12 inches in diameter by 5 or 10 feet long, containing a 4-inch perforated pipe surrounded by EPS aggregate, with a prefabricated geotextile barrier material.
2. The **EZflow** 1202H product is 12 inches in diameter by 5 or 10 feet long. One of the polyethylene net bundles contains expanded polystyrene aggregate only and one contains a four-inch pipe surrounded by EPS aggregate, with a prefabricated geotextile barrier material.
3. The **EZflow** 1203H product is 12 inches in diameter 5 or by 10 feet long. Two of the polyethylene net bundles contain expanded polystyrene aggregate only and one contains a four-inch pipe surrounded by EPS aggregate.

In cases where linear footage required is not in multiples of 5 or 10, the installer may (a): reduce the product to the needed length and refasten the netting to the pipe or, (b): use an additional 5' or 10' of product to exceed the required trench length.

1. After the local health department has determined sizing, configuration, and layout for the **EZflow** systems, stake or mark with paint the location of trenches and lines. Be careful to set correct tank, invert pipe, header line or distribution box and trench bottom elevations before installation of pipe bundles.
2. If smearing or glazing of trench sidewalls and bottom has occurred in clay soils, it is recommended that these soil surfaces be raked or scarified.
3. The proper elevation of solid PVC effluent pipe going to each trench should be determined to ensure compliance with the required maximum trench bottom depth as shown on the approved permit. This height may vary dependent on system height and configuration used.
4. Remove **EZflow** stretch wrap prior to placing bundles in the trench(es). Remove any stretch wrap in the trench before system is covered.
5. Place **EZflow** bundle(s) in the **EZflow** configuration approved by system design permit specified for the particular site. The top or center-most bundles containing pipe are joined end to end with an internal pipe coupler. Any additional aggregate only bundles that may be required, should be butted against the other aggregate-only bundles and do not require any type of connection.
6. The top of each 1201-P-GEO, 1202H-GEO, and 1203H-GEO cylinder contains a filter fabric pre-manufactured in between the netting and aggregate. The fabric is inserted to prevent soil intrusion. The installer shall make sure that the fabric is positioned upward and is in contact with the fabric contained in the adjacent cylinder before backfilling.
7. Header or lead lines from distribution box or device will be connected to the top or center-most pipe bundle in each trench or inserted into the pipe.
8. The **EZflow** Drainfield Systems should be installed in a level trench in all directions (both across and along the trench bottom) and should follow the contour of the ground surface elevation (uniform depth), with all continuous adjoining 10-foot cylindrical bundles placed end to end, with the central bundle distribution pipe interconnected, without any dams, stepdowns or other water stops.
9. When surface slopes are greater than two percent, the bottom of the nitrification trenches shall follow the contour of the ground. An engineer's level or equivalent shall be used for installation and inspection.

10. **EZ_{flow}** EPS bundles are flexible and can fit in curved trenches as may be necessary to avoid trees, boulders, or other obstacles.
11. The soil cover over the nitrification field should be to a depth of at least 12 inches.
12. The finished grade over the nitrification field should be landscaped to prevent the ponding of surface water.
13. Soil cover above the original grade should be placed at a uniform depth over the entire nitrification field, except as required to prevent the ponding of surface water.
14. The soil cover should be placed over nitrification field after proper grading of the original ground surface.

Repeat steps 1 thru 14 for each required trench.

The area of the disposal field shall not be used for vehicular traffic or parking or underground utilities to include water lines. Dozers, trucks, and other heavy vehicles shall not be allowed to run over the septic tank, field lines or other parts of the system.

Sod or seed the drainfield area to control erosion, as may be required by Permit or local policy.

EZ_{flow} Inspection

As required by state or local regulations, be sure to obtain proper installation inspection and authorization from the health department prior to covering the system.

Septic tank, header pipe or D box, trench bottom, grade, depth, and cover shall be in accordance with state rules and regulations unless otherwise specified.

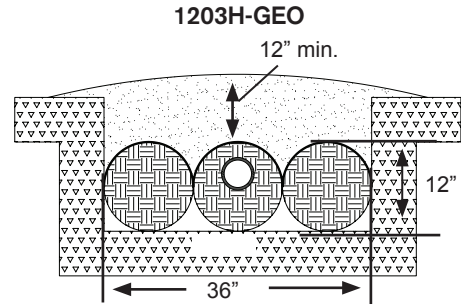

EXAMPLE: 300 sq. ft. required.
 $300 \text{ sf} \div 4 = 75 \text{ lin. ft. required}$

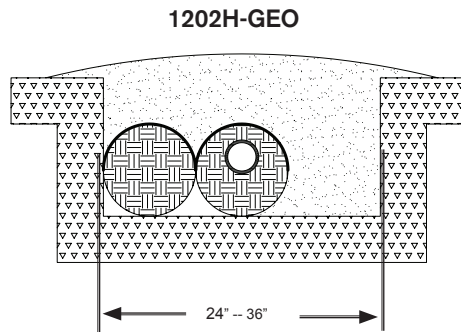

EXAMPLE: 300 sq. ft. required.
 $300 \text{ sf} \div 2.67 = 112 \text{ lin. ft. required}$

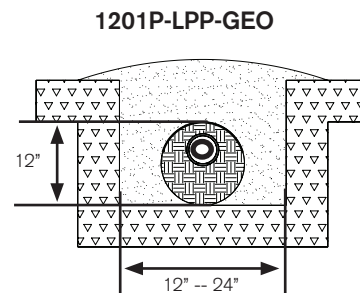

INFILTRATOR[®]
 systems inc.

6 Business Park Road • Old Saybrook, CT 06475 • 800.689.7759