

Installation Instructions for EZflow Systems in Tennessee



Tennessee Department of Environment and Conservation, Ground Water Protection, granted product approval per TCA Section 68-221-Part 4 for use of **EZflow** by Infiltrator brands 1203H, 1203H-GEO, 1401-P, and 1401-P-GEO.

The **EZflow** 1203H-GEO and 1203H are approved as wastewater dispersal systems and sized at a thirty (30) percent reduction of the required linear foot sizing for the standard three (3) feet wide conventional gravel media trench for soil absorption rates of ten (10) through sixty (60) minutes per inch. Permits in soil rated above sixty minutes per inch shall be installed foot per foot as with conventional. This product is installed in a 36-inch wide trench.

The **EZflow** 1401-P-GEO and 1401-P are approved as wastewater dispersal systems and sized foot for foot as with conventional 3 foot wide systems, with no length reduction given.

Any site where **EZflow** products 1203H, 1203H-GEO, 1401-P, or 1401-P-GEO are installed must meet the same site, soil, soil evaluation, repair area, construction, and all other requirements imposed for a standard gravel drainfield.

An area of suitable soil must be available to install and duplicate a conventional subsurface sewage disposal system.

Infiltrator Systems Inc. shall certify installers during or prior to their first installation as having passed **EZflow** Certification Training.

Materials and Equipment needed

- **EZflow** Bundles
- **EZflow** Barrier Paper
- **EZflow** Internal Pipe Couplers
- Pipe for Header and Inlet
- Backhoe
- Laser, Transit, or Level

Installation Instructions

The instructions for installation of **EZflow** products are given below. This product must be installed in accordance with TDEC Regulations Chapter 1200-1-6 (Rev. 1-31-06).

In cases where linear footage required is not in multiples of 10, installer may use an additional 5 feet or 10 feet of product to exceed the required trench length.

1. After sizing has been determined, along with configuration, and layout for the **EZflow** systems, stake or mark with paint the location of trenches and lines. Be careful to set correct tank, invert pipe, header line and trench bottom elevations before installation of pipe bundles.
2. Trenches shall not be excavated when the soil is wet enough to smear or compact easily. If smearing or glazing of trench sidewalls and bottom has occurred in clay soils, it is recommended that these soil surfaces be raked or scarified.
3. The disposal field is to be a recirculating or serial distribution type or modification of either, depending on site characteristics.
4. Disposal field trenches shall follow the ground surface contours so that variations in trench depth will be minimized.

5. A minimum of six (6) feet of undisturbed earth, between trenchwalls is required. Other separation distances shall be as per Section 1200-1-6-.10.
6. When installed in a trench, the trench should be dug to a width of 36 inches for 1203H; width of 14"-20" for 1401-P. Minimum cover depth shall comply with permit specifications. This not only saves labor in excavation, but also provides better load-bearing capacity after backfilling is complete.
7. Remove plastic **EZflow** stretch wrap prior to placing the bundles in the trench(es). Remove any plastic wrap in the trench before system is covered.
8. Place **EZflow** bundle(s) in the **EZflow** configuration approved by system design permit specified for the particular site. The center-most bundles containing pipe are joined end to end with an internal pipe coupler. Any additional aggregate only bundles that may be required, should be butted against the other aggregate-only bundles and do not require any type of connection.
9. The top of configurations with the Suffix "GEO" contains a filter fabric pre-manufactured in between the netting and aggregate. The fabric is inserted to prevent soil intrusion. The installer shall make sure that the fabric is on top and is in contact with the fabric contained in the adjacent cylinder before backfilling.
10. Supply lines will be connected to the center-most pipe bundle in each trench or inserted into the pipe.
11. When using serial distribution, crossovers should be constructed at the distal end of trench when possible. When necessary, crossovers may be constructed between bundle length utilizing a "T" Coupler.
12. The bottom of the trenches and distribution lines shall have a grade from level to no greater than four (4) inches.
13. **EZflow** EPS bundles are flexible and can fit in curved trenches as may be necessary to avoid trees, boulders, or other obstacles.
14. If not utilizing a GEO product, **EZflow** 1203H should use the 4-foot wide untreated building paper or two runs of 3-foot paper. **EZflow** 1401-P should use the 2-foot wide untreated building paper. Other barrier material may be used as approved by TDEC and manufacturer.
15. Soil material excavated from trenches should be used in backfilling and should be left mounded over trenches until initial settling has taken place. Soil within 6" of EPS bundles shall be loosely placed and not compacted.

Repeat steps 1 thru 15 for each required trench.

Approved EZflow Products

EZflow 1203H/1203H-GEO

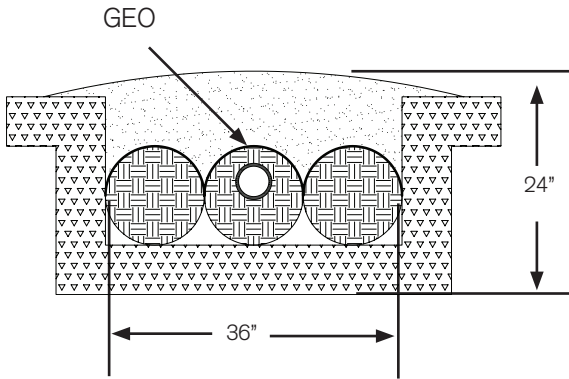

EXAMPLE: 300 sq ft. required
 $900 \text{ sf} \div 4 \text{ sf/ft} = 210 \text{ ft required}$

Properties and Specifications

Overall Bundle Diameter	12"
Trench Length Modification*	30%
Trench Width	36"
Trench Depth	24"

* 30% trench length modification allowed for Percolation Rates of 60 minutes per inch and below. Foot for foot sizing required above Percolation Rate of 60 minutes per inch.

EZflow 1401P/1401P-GEO

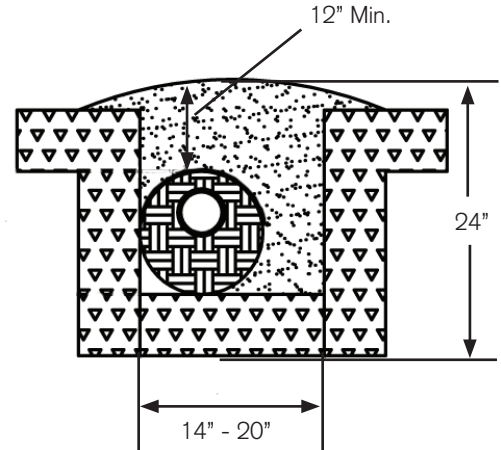

1401P is sized on a foot per foot basis.

Properties and Specifications

Overall Bundle Diameter	14"
Trench Length Modification**	0%
Trench Width	14" - 20"
Trench Depth	24"

**Foot for foot sizing for Percolation Rates up to 100 minutes per inch. No sand or gravel backfill required.

LPP Systems EZflow 1201P-LPP

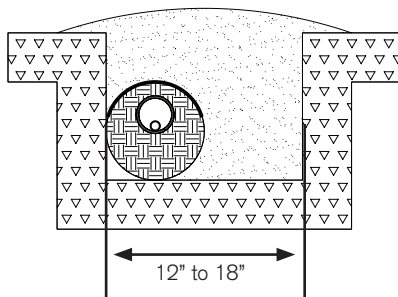

GWP has determined that the **EZflow** 1201P meets the intent of the regulations where suitable soil depths are demonstrated to be at least thirty-three (33) inches and will be allowed as a media substitute for LPP systems in these situations.

The **EZflow** 12" bundle shall be oriented in the trenches such that there are 6" of polystyrene (EPS) aggregate below the 4" diameter High Density Polyethylene (HDPE) pipe, meeting ASTM F-405. The 4" diameter HDPE pipe shall house the LPP laterals.

LPP systems using the **EZflow** 1201P shall be sized equivalent to that of LPP systems using disposal field media as specified in Rule 1200-1-6-.14(3) of the regulations. Note, because of the twelve (12) inch diameter, utilization of 1201P will necessitate a minimum total soil depth to restrictive horizon of thirty-three (33) inches and a minimum disposal field trench depth of twenty-one (21) inches.

.....

The area of the disposal field shall not be used for vehicular traffic, parking, or underground utilities, to include water lines. Dozers, trucks, and other heavy vehicles shall not be allowed to run over the septic tank, field lines or other parts of the system.

Sod or seed the drainfield area to control erosion, as may be required by Permit or local policy.

Maintenance

It is the property owner's responsibility to maintain the system in a safe and sanitary manner per Section 1200-1-6.12.

EZ_{flow} Inspection

As required by state or local regulations, be sure to obtain proper installation inspection and authorization from the health department prior to covering the system.

Septic tank, header pipe or D box, trench bottom, grade, depth, and cover shall be in accordance with state rules and regulations unless otherwise specified.

.....



INFILTRATOR[®]
systems inc.

6 Business Park Road • Old Saybrook, CT 06475 • 800.689.7759