

Installation Instructions for EZflow Systems in North Carolina



The North Carolina Department of Environment and Natural Resources Division of Environmental Health On-Site Wastewater Section approved the use of **EZflow** by Infiltrator drainfields as a replacement for conventional drain media in both gravity and pressure-dosed effluent disposal trench systems. **EZflow** drainfields are also adaptable to serial and drop box distribution in accordance with requirements for conventional trenches as described in administrative code 15A NCAC 18A.1955 in conjunction with manufacturers recommendations for installation.

Prior to installation, Infiltrator Systems Inc. must certify installers in writing as having passed **EZflow** Certification Training.

Materials and Equipment needed

- **EZflow** Bundles
- **EZflow** Barrier Paper
- **EZflow** Internal Pipe Couplers
- Pipe for Header and Inlet
- Backhoe
- Laser, Transit, or Level
- Shovel and Rake

Installation Instructions

The instructions for installation of **EZflow** products are given below. This product must be installed in accordance with state rules defined in North Carolina Department of Environment and Natural Resources Division of Environmental Health On-Site Wastewater Section, administrative code 15A NCAC 18A.1955, as well as the local health department's current design manual.

The **EZflow** bundles are 12 inches in diameter by 5 or 10 feet long. The polyethylene net bundles contain perforated pipe surrounded by EPS aggregate.

In cases where linear footage required is not in multiples of 5 or 10, the installer may (a): reduce the product to the needed length and refasten the netting to the pipe or, (b): use an additional 5' or 10' of product to exceed the required trench length.

1. After the local health department has determined sizing, configuration, and layout for the **EZflow** systems, stake or mark with paint the location of trenches and lines. Be careful to set correct tank, invert pipe, header line or distribution box and trench bottom elevations before installation of pipe bundles.

2. If smearing or glazing of trench sidewalls and bottom has occurred in clay soils, it is recommended that these soil surfaces be raked or scarified.

3. The proper elevation of solid PVC effluent pipe going to each trench should be determined to ensure compliance with the required maximum trench bottom depth as shown on the approved permit. This height may vary dependent on system height and configuration used.

4. Each trench system must have a minimum separation between trench walls as required by 15A NCAC 18A.

5. Remove EZflow stretch wrap prior to placing bundles in the trench(es). Remove any stretch wrap in the trench before system is covered.

6. Place EZflow bundle(s) in the EZflow configuration approved by system design permit specified for the particular site. The top or center-most bundles containing pipe are joined end to end with an internal pipe coupler. Any additional aggregate only bundles that may be required, should be butted against the other aggregate-only bundles and do not require any type of connection.

7. Header lines can be connected to the pipe containing **EZflow** bundle with the **EZflow** Versa Coupler™. Connect a standard 4-inch internal coupler into the **EZflow** product and simply snap the Versa Coupler onto the 4" coupler. The opposite end of the Versa Coupler is designed to connect to either 4" SDR 35 or 4" SCH 40 with a standard primer and glue seal.

8. The top of each 1203H-GEO cylinder contains a filter fabric pre-manufactured in between the netting and aggregate. The fabric is inserted to prevent soil intrusion. The installer shall make sure that the fabric is on top and is in contact with the fabric contained in the adjacent cylinder before backfilling. The end-to-end gap distance between pipe containing GEO bundles, as measured from the straps fixing the netting to the pipe or from the face edges of aggregate on adjoining bundles, should be no greater than 3 inches.

9. If not using a GEO product, **EZflow** systems require covering over the top of the system with a biodegradable material approved by the manufacturer.

10. Header or lead lines from distribution box or device will be connected to the top or center-most pipe bundle in each trench or inserted into the pipe.

11. The **EZflow** Drainfield Systems should be installed in a level trench in all directions (both across and along the trench bottom) and should follow the contour of the ground surface elevation (uniform depth), with all continuous adjoining 10-foot cylindrical bundles placed end to end, with the central bundle distribution pipe interconnected, without any dams, stepdowns or other water stops.

12. When surface slopes are greater than two percent, the bottom of the nitrification trenches shall follow the contour of the ground. An engineer's level or equivalent shall be used for installation and inspection.

13. **EZflow** EPS bundles are flexible and can fit in curved trenches as may be necessary to avoid trees, boulders, or other obstacles.

14. The soil cover over the nitrification field should be to a depth of at least six inches.

15. The finished grade over the nitrification field should be landscaped to prevent the ponding of surface water.

16. Soil cover above the original grade should be placed at an uniform depth over the entire nitrification field, except as required to prevent the ponding of surface water.

17. The soil cover should be placed over nitrification field after proper preparation of the original ground surface.

Repeat steps 1 through 17 for each required trench.

As required by state or local regulations, be sure to obtain proper installation inspection from the health department prior to covering the system.

After the system has been completely covered, only drive across the trenches when necessary. Never drive along the trench lines. To avoid additional soil compaction, prevent any heavy equipment from driving across or along the trench lines.

Sod or seed the drainfield area to control erosion, as may be required by Permit of local policy.

Sizing

1. The maximum long-term acceptance rate (LTAR) shall be as shown in 15A NCAC 18A. 1955 Design Installation Criteria for Conventional Sewage Systems, Table II.

2. The LTAR shall be based on the most hydraulically limiting naturally occurring soil horizon within three feet of the ground surface or to a depth of one foot below the trench bottom, whichever is deeper.

3. To determine the minimum total trench bottom area (ft²) required, divide the design daily sewage flow by the applicable LTAR shown in Rules Table II. The minimum linear footage for EZflow drainfield systems shall be determined by dividing the total trench bottom area by the following equivalency factors:

Model	Equivalency Factor
1003T	3.00
1203H	4.00
1203T	4.00
1203H-GEO	4.00

4. Examples of sizing calculations are shown with the configuration drawings.

How to set up a EZflow system in North Carolina:

1003T approved at 3.00 ft²/ft

450 ft² of trench bottom area required

450 / 3.0 = 150 linear feet of 1003T required

Operation and Maintenance

Operation and maintenance for EZflow 1203H-GEO utilizing an equivalency of 4.0 or less shall have a minimum classification of IIa. All other EZflow drainage systems shall have a minimum classification as a Type IIIg system (other non-conventional trench systems) in accordance with Table V(a) of Rule 15A NCAC 18A. These recommendations include: avoiding excessive amounts of water, grease or non-biodegradable materials entering the septic tank, promoting even wastewater distribution, avoiding chemical or biological additives, promoting ready access to the septic tank for maintenance and periodic inspection and pumping of the septic tank.

System Inspection

Provisions of the NC Rules apply, except as modified by Innovative Wastewater No: IWWWS-95-3R. Inspection is significantly easier due to the pre-assembly of the components. Levelness of the trench bottom may be checked by inserting a rod between the aggregate bundles down to the trench bottom. Poor quality stone and/or excessive fines are never a concern. The lack of required depth of aggregate is never a problem.

Approved EZflow Products

EZflow Bed Systems

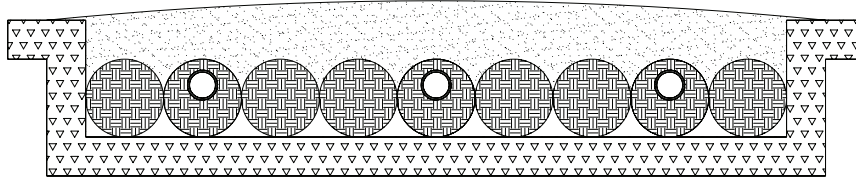

The EZflow Drainage System 1203H configuration may be used in a bed system with the three cylindrical bundles placed in rows next to each other. The minimum area (without reduction or equivalency factor) for a bed system shall be determined as required in 15A NCAC 18A.1955(d). This configuration is installed at foot for foot with a conventional gravel bed system.

EZflow 1203H-GEO

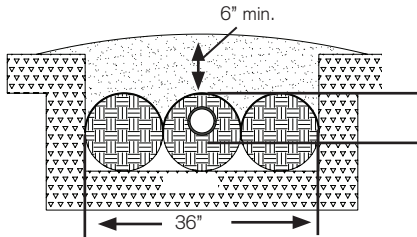

1203H-GEO Approved at 4. sf/ft

EXAMPLE: 300 sq. ft. required.
 $300 \text{ sf} \div 4.0 = 75 \text{ lin. ft. required}$

or **1203H-GEO Approved at 4.61 sf/ft**
 (5-Year Warranty System)

EXAMPLE: 300 sq. ft. required.
 $300 \text{ sf} \div 4.61 = 65 \text{ lin. ft. required}$

EZflow 1203T/1203T-GEO

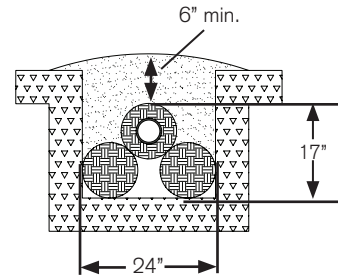

EXAMPLE: 300 sq. ft. required.
 $300 \text{ sf} \div 3.0 = 100 \text{ lin. ft. required}$

EZflow 1201P/1201P-GEO

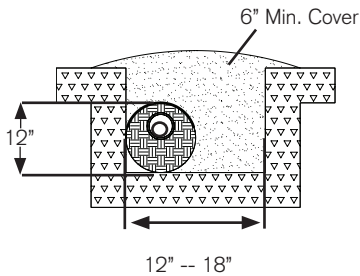

The central cylinder of the 1203H or 1203H-GEO which contains the offset four-inch pipe may be used as an alternative to rock aggregate in a low pressure pipe (LPP) system, sized equivalent to LPP systems as required in 15A NCAC 18A.1957(a).

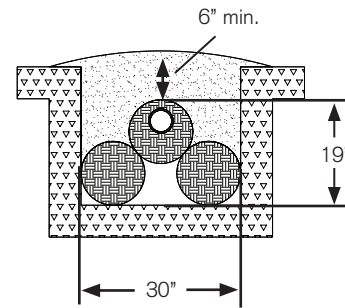

1203T Approved at 4 sf/ft

EXAMPLE: 300 sq. ft. required.
 $300 \text{ sf} \div 4.0 = 75 \text{ lin. ft. required}$

or

1203T Approved at 4.61 sf/ft
 (5-Year Warranty System)

EXAMPLE: 300 sq. ft. required.
 $300 \text{ sf} \div 4.61 = 65 \text{ lin. ft. required}$

Product Specifications	1003T	1203H-GEO	1203T	1201P LPP	1203H BED
Overall System Height	17"	12"	19"	12"	12"
Trench Width	24"	36"	30"	12" - 18"	-
Equivalency Factor*	3	4	4	-	-
	-	4.61 (Warranty Sys.)	4.61 (Warranty Sys.)	-	-
Minimum Cover	6"	6"	6"	6"	6"
Minimum Trench Spacing	7.5'	9.0'	9.0'	-	-
Min. Trench Depth Below Finished Grade**	23"	18"	25"	18"	18"
Max. Trench Depth Below Finished Grade	36"	60" ***	36"	36"	36"
Min. Pipe Invert Depth Below Finished Grade**	11"	12"	12"	12"	12"
Min. Pipe Height Above Trench Bottom	10"	6"	11"	6"	6"

* The design (equivalent) trench width and equivalency factor shall not exceed the excavated trench width for systems installed in fill or food service facilities, meat markets, and other places of business where accumulation of grease can cause premature failure of soil absorption systems. Reductions in trench bottom area up to those allowed by applying Design (equivalent) trench width and equivalency factors may be permitted for facilities where data from comparable indicate that grease and oil content of the effluent will be less than 30 mg/l and the chemical oxygen demand (COD) will be less than 500 mg/l.

** Note that on sloping lots, minimum required trench depths shall be greater.

*** 1203H-GEO systems installed at depths greater than 36" shall be sized with an equivalency factor of 3.



INFILTRATOR®
systems inc.

6 Business Park Road • Old Saybrook, CT 06475 • 800.689.7759